

standard

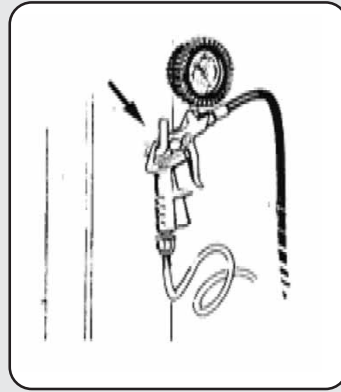

› Inflation gun with manometer
PN: 100182

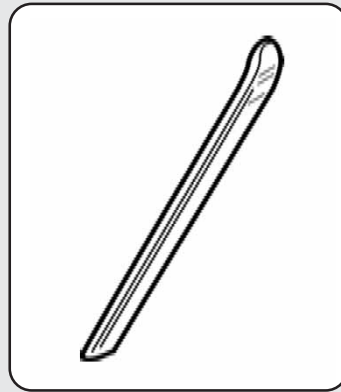

› Bead lever

optional

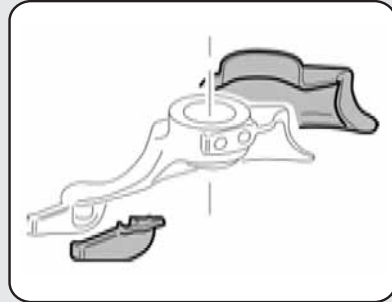

› Tower tab - PN: 200130
› Mounting head protector
PN: 200272



› Side guard kit
PN: 200589

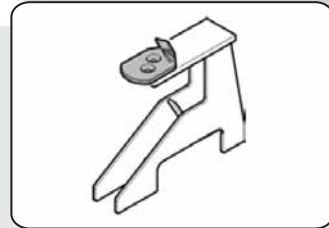

› Motorbike adaptor
PN: 200604

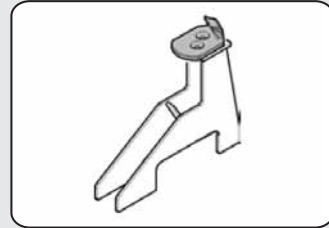

› Scooter adaptor
PN: 200606

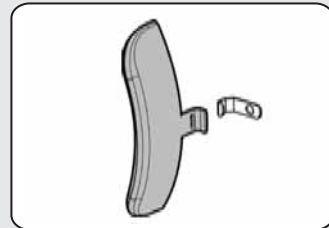

› Kit for bead breaker tool
PN: 200215



› Michelin inflation gun
PN: 100180

package

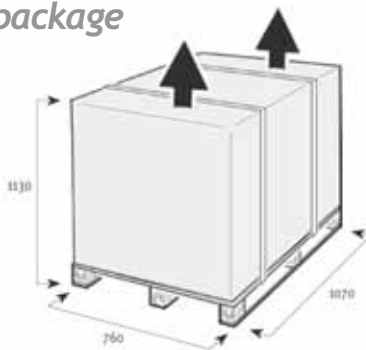

dimensions

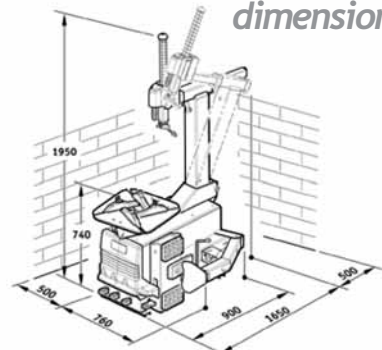

package Tecnohelp

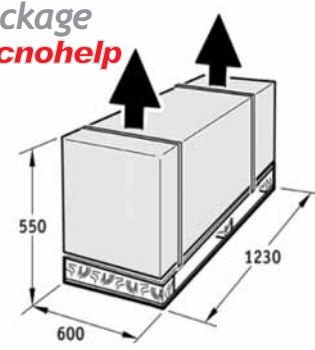

technical data

bal.co.za	Net weight	Electric motor	Operating pressure	Bead breaker force	Max wheel diameter	Wheel width	Rim diameter (locked internally)	Rim diameter (locked externally)
TC522-3PH	220 kg	1.2/0.9kw 3PH 400V	8-12 bar	2500 kg	1160 mm (46")	3" - 16"	12" - 23"	10" - 20"
TC522IT-3PH	238 kg							
TC528-3PH	220 kg	1.2/0.9kw 3PH 400V	8-12 bar	2500 kg	1160 mm (46")	3" - 16"	12" - 31"	10" - 28"
TC528IT-3PH	238 kg							

Snap-on
Equipment
OFFICIAL SUPPLIER

National Customer Services Center:

Tel: 0861 SNAPON (762766) | Fax: 0861 762767 | E-mail: equipment@snapon.co.za
National Sales Director: Cell: 082 551 5388

bal.co.za

tyre changers

- › Automatic tyre changer for car, motorcycle and light industrial vehicle
- › Equipped with 2 speed turn table electric motor
- › This machine is equipped with a new generation jaws designed to work on aluminium wheels from 10" to 31" inside rim and 12" to 28" outside rim
- › All the positioning movements are automatic to speed up operating procedures
- › Its toughness and reliability are the main features of the machine, its suitable to work in a easy and effective way on wide tyre particularly
- › Standard with special 4 position pneumatic bead breaker
- › *tecnohelp* optional



TC528-3PH

* *Tecnohelp* optional

bal.co.za

tyre changers

- › Automatic tyre changer for car, motorcycle and light industrial vehicle
- › Equipped with 2 speed turn table electric motor
- › This machine is equipped with a new generation jaws designed to work on aluminium wheels from 10" to 23" inside rim and 12" to 20" outside rim
- › All the positioning movement are automatic to speed up operating procedures
- › Its toughness and reliability are the main features of the machine
- › Standard pneumatic bead breaker version

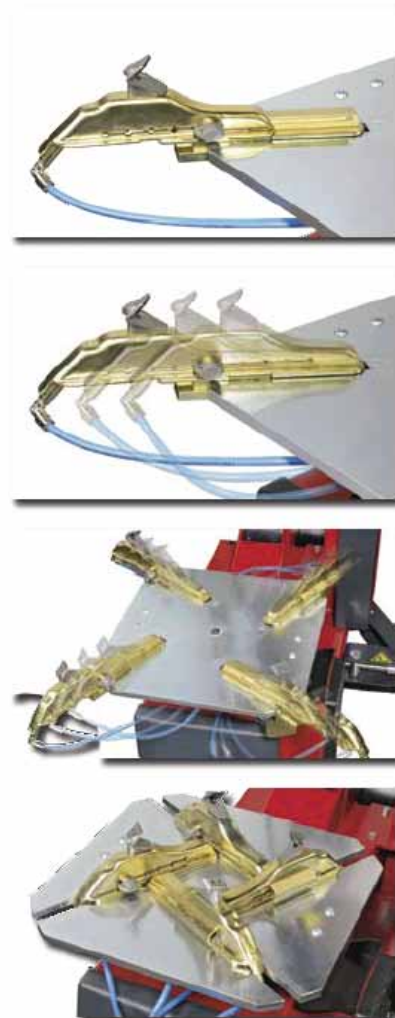

IT (Inflator Tubless) Version (special order only)

- › The most efficient tubeless inflation system available
- › The IT device provides a supplementary air circuit with direct passage to the outlets in each rim well, permitting the beading in any type of tyre.
- › PG versions include an inflation device fitted with a fixed control instrument with graduated scale and pedal control (standard feature on the IT version).

Tecnohelp

- › A professional tool that is indispensable for dealing with wide and low profile tyres (EMT, RFT, CRS, DSST, etc.) as well as particularly hard or large sized tyres.
- › The tough structure designed with 2 air cylinders of 80 mm does not allow flexing during the hardest working operations.
- › Easy to fit on all automatic machines that are already predisposed.



Helper

- › This is an additional bead-pushing device to be fitted with the *tecnohelp*
- › It assists during the mounting and demounting of the 1st bead.
- › It is particularly suited to tyres and rims of large diameters and sizes



- › The fixed arm has a graduated gauge to assist operators during the positioning and control of the arm
- › The movable arm (Fig. A) makes it possible to keep the bead pushed into the rim-well during mounting
- › The fixed arm can be positioned under the lower part of the tyre.
- › A three-colour sticker always indicates the working position of the arm, simplifying the operator's work.



Special 4 position pneumatic bead breaker

- › The special shape and dimensions of the column and bead-breaker make these machines particularly suited for working on large wheels (over 15" in width)
- › The bead-breaking cylinder is double acting with internal nylon protection
- › S versions are provided with a special device that makes it very easy to adjust the opening range of the bead-breaking plate.
- › The *TC528-3HP* is fitted standard with the S version bead-breaker and is particularly suited to rims and tyres of large diameters and sizes.